



QuickChange™ Strut Brace - Instructions

Part # 2162215

Cars applicable:

996, 986

Parts list:

Quantity	Description
2	Front Brackets
2	Nut Plate Assemblies
1	Rear Bracket Left Side
1	Rear Bracket Right Side
1	X-Brace Long assembly
1	X-Brace Medium assembly
1	X-Brace Short assembly
8	M6 socket head cap screws
8	M6 Wavy Washers
4	M6 Flange Locking Nuts
4	Quick Release Pins

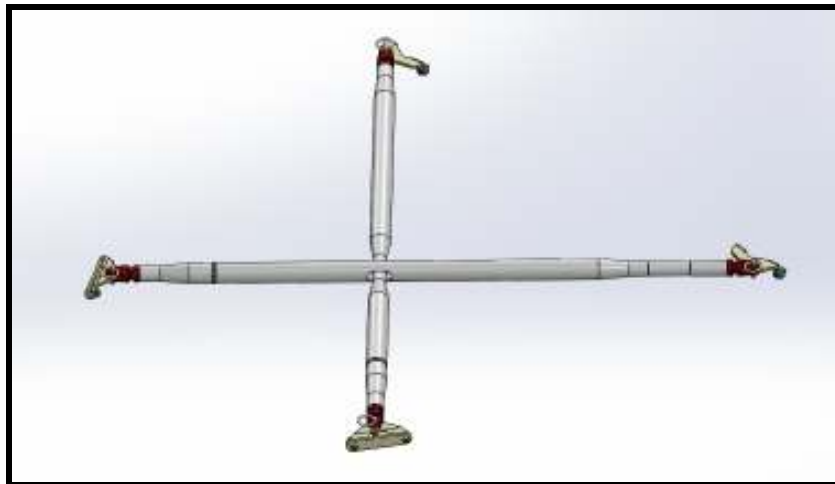

Tools Required:

- 5/16" drill bit and drill
- 1 3/8" drill bit or other cutting tool
- razor knife
- 5 mm Hex Key
- 10mm wrench
- Flat blade screwdriver

Introduction:

Congratulations on your purchase of the QuickChange Strut Brace from Elephant Racing!

Once installed, the QuickChange strut brace system allows for tool-less removal, allowing you to retain use of your front storage space when you need it.

Before beginning:

Your brace will attempt to hold any twist in the chassis at the time of installation. Perform installation on flat ground with proper tire inflation to avoid chassis twist.

Assemble all brace assemblies without preload –neutral– neither in compression or tension. This will ease installation / removal of the Quick Release pins and provide the best overall performance under the alternating loads presented by left and right cornering and braking.

Read the entire instructions before beginning.

Step-by-Step Installation -

1 – Interior removal

Remove the carpet and weather strip material from the front trunk area of the vehicle. Use a flat blade screwdriver to undo the quarter turn fasteners attaching the plastic hood latch cover to the car. Remove the plastic covering the brake master cylinder.

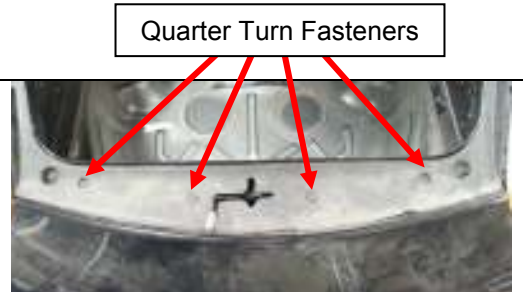

2 – Electrical Connector Removal

Detach the electrical connector near the driver's side strut tower. Disconnect the two halves of the electrical plug as shown to the right by first pulling up on the lock tab and pulling the two halves apart. Move and tape the wires out of the way so they do not impede installation.

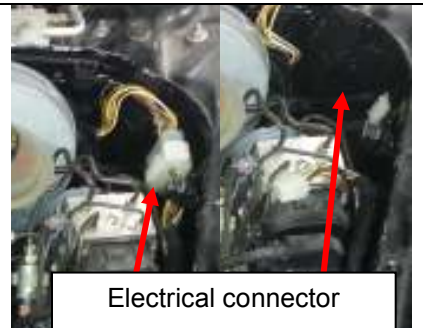

3 – Front Bracket Installation

The brackets to attach the X brace to the chassis are to be attached to the locations as shown to the right.

Position the front bracket along the chassis as far forward as possible. Mark the location of the bracket holes for drilling.

Using a size 5/16" drill bit, drill holes for the M6 fasteners to attach the mounting plate.

Place a shop towel or rag on the outside of the chassis crevice to prevent the nut plate from falling into the chassis during installation. Slide one of the M6 nut plates into the chassis crevice (see photo to the right). Using the supplied M6 hardware, attach the front bracket to the nut plate.

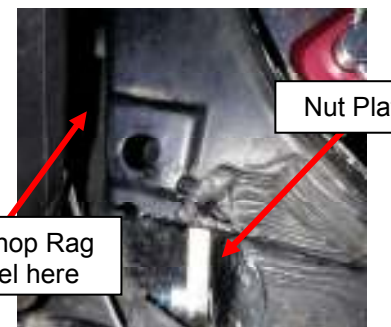

4 – Driver's Side Rear Bracket Installation

Thread the clevises into the long tube before beginning. Position the long X-brace assembly such that the end with reliefs cuts passes between the brake hard lines and the ABS module. Attach the left side rear bracket to the long X-brace assembly using the supplied quick release pins. Attach the other end of the assembly to the front bracket installed in step 3.

Ensure that the X-brace assembly clears the ABS module and brake lines.

The clevis ends are left and right threaded, such that the assembly can be shortened or lengthened by rotating with the clevis's anchored. Extend the assembly until the rear bracket meets the chassis sheet metal. Using the bracket as a guide, mark the hole furthest outboard for drilling. Drill the hole using a 5/16" bit.

With the wheel removed and working from inside the wheel well, use the supplied template to mark and drill the second hole for the bracket. Use the supplied hardware to attach the rear bracket to the chassis.

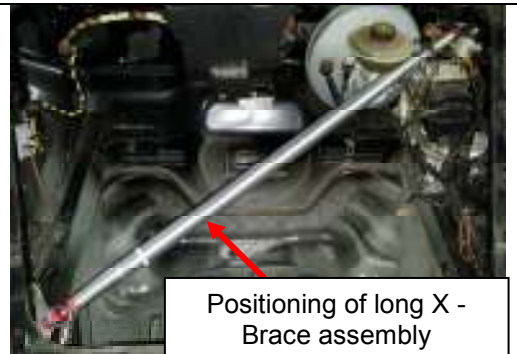

Positioning of long X - Brace assembly

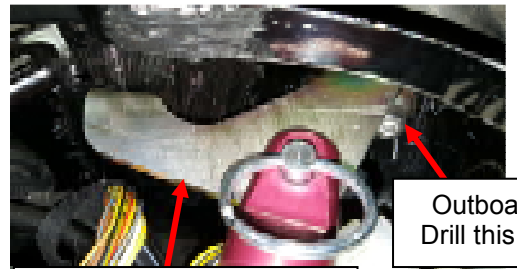

Outboard Hole: Drill this hole first

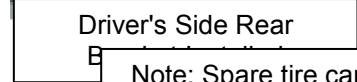

Driver's Side Rear Bracket
Note: Spare tire can still be kept in the front trunk with X-Brace installed

5 – Right Side Rear Bracket Installation

Thread the short and medium tubes together through the oval cutout in the long assembly. The short assembly should be closest to the front of the car, with the medium length assembly closest to the rear.

Attach the assembly to the front bracket installed previously. Attach the right side rear bracket to the other end. Lengthen until the bracket meets the chassis sheet metal. Ensure that the assembly is centered in the oval cutout of the long assembly. Mark the locations of the bracket holes on the chassis for drilling.

Use a 5/16" drill bit to drill holes in the chassis for the M6 fasteners to attach the bracket to the chassis. Use the supplied hardware to attach the rear bracket to the chassis.

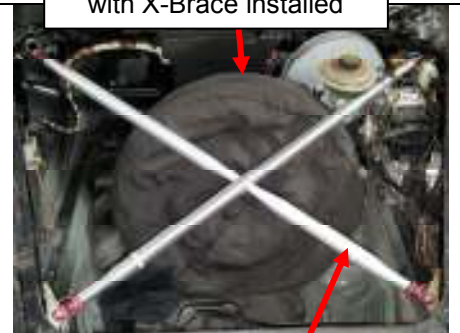

Positioning of combined short and medium length X - Brace bar

6 – Trim and upholstery installation

Temporarily remove the X brace assemblies, leaving the brackets in place. Install the carpet in the reverse order of removal.

The carpet around the forward brackets can be trimmed using a sharp pair of scissors or razor knife. See photo to the right for an example. A template is provided at the end of these instructions to simplify the carpet cutting process.



Template taped in place on back side of plastic cover

To install the plastic brake master cylinder cover, a section must be cut so that the plastic cover can be slid over the assembly. Use the provided template for proper hole placement.

The template is to be placed on the back side of the plastic cover as shown to the right. Tape the template to the plastic cover such that the crease of the template flap rests in the corner of the protruding plastic near the trunk light. The bottom edge of the template should line up with the edge of the cover as shown to the right. The template should be aligned in such a way that the curved tab at the top rests around the cutout for the brake fluid reservoir.

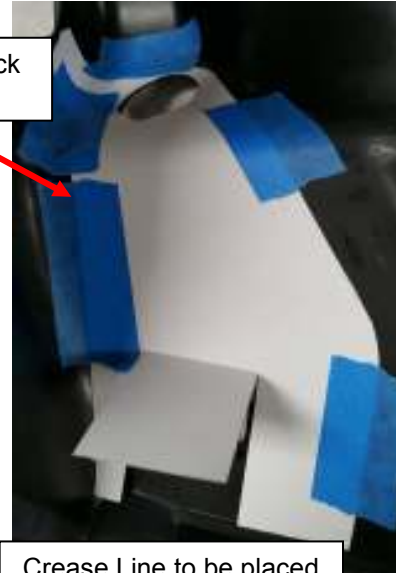

Crease Line to be placed in corner of feature

The bottom edge of the template is then to line up. When drilling the hole, use a pilot hole to establish the center then increase in size until reaching 1-3/8". Then angle the drill bit to point towards the left side rear bracket. This will cut the requisite oval shape to allow the assembly to pass through the plastic.

The above method gives a very clean install, but the hole can be cut using a razor knife or other cutting tools.



Bottom edge of template to be placed at edge of

Curved edge of template to contour to rounded edge for brake fluid reservoir



Install the large assembly clevises into the brackets using the quick release pins. Snug down the jam nuts finger tight. The cover may then be secured in place as normal using the factory hardware.



Locate the position on the carpet where the medium assembly needs to pass. Use a razor knife to cut an "X" in the carpet. Re-install the medium assembly through the "X" cut.



Bend over the corner of the carpet can the large assembly clevises into the brackets using the quick release pins. Snug down the jam nuts finger tight.





This page intentionally blank.

Templates:

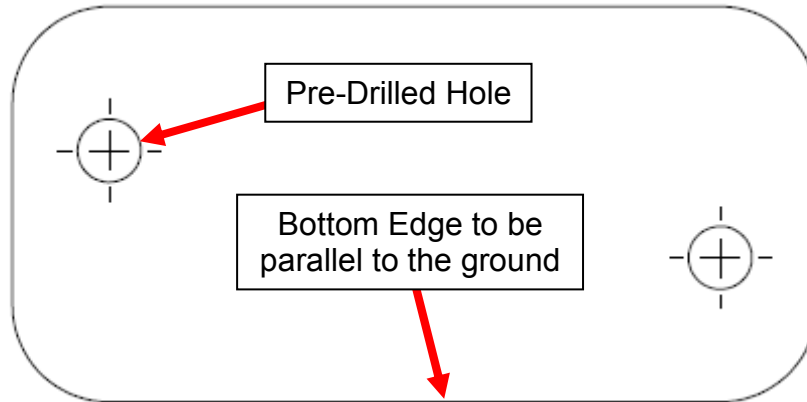

Figure 1: Left Side Rear Bracket Template

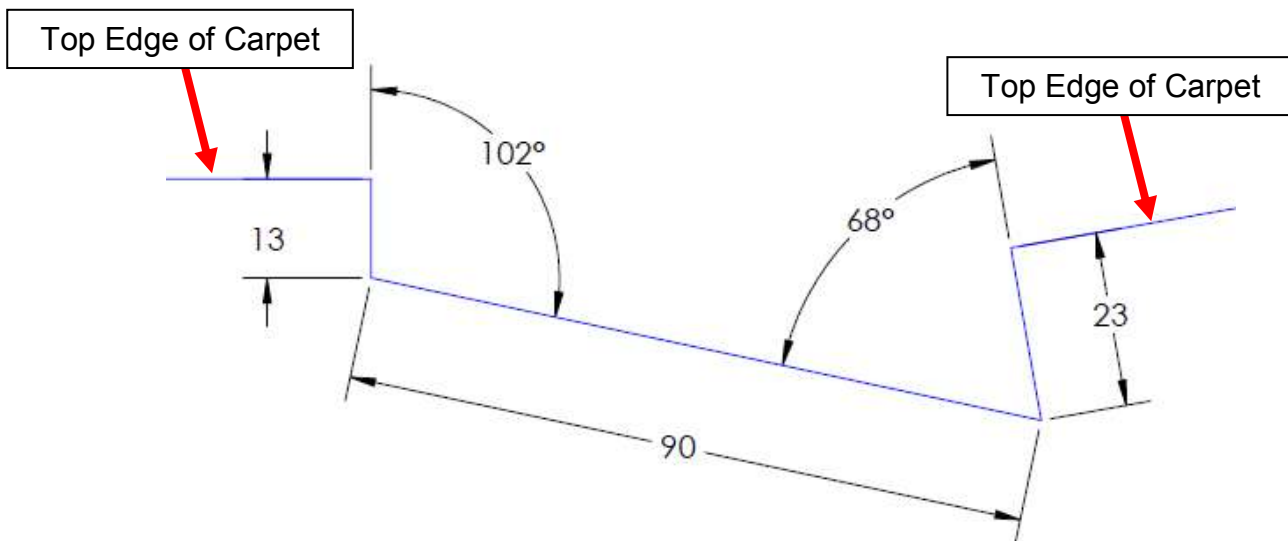

Figure 2: Forward Bracket Carpet Cutout Template (left side template shown. Flip over when using as right side template)

