



PolyBronze™ Trailing Arm Bearings - Installation Instructions

Part #2400800 - Patent Pending

Cars applicable:

All 914

Parts list:

Qty	Description
4	PolyBronze Bearing
2	Pivot shaft
4	Thrust washer
4	Angled Grease fitting
4	Flat washer

Introduction –

PolyBronze Trailing Arm Bearings replace the rubber bushings and axles that allow the trailing arm to pivot. The bearings provide improved road feel and handling. They do not compress under load and therefore maintain suspension alignment settings.

PolyBronze Trailing Arm Bearings are installed with grease fittings making periodic re-lubrication easy.

Note – PolyBronze Trailing Arm Bearings should be lubricated at installation and 5,000 mile intervals. Use quality moly grease.

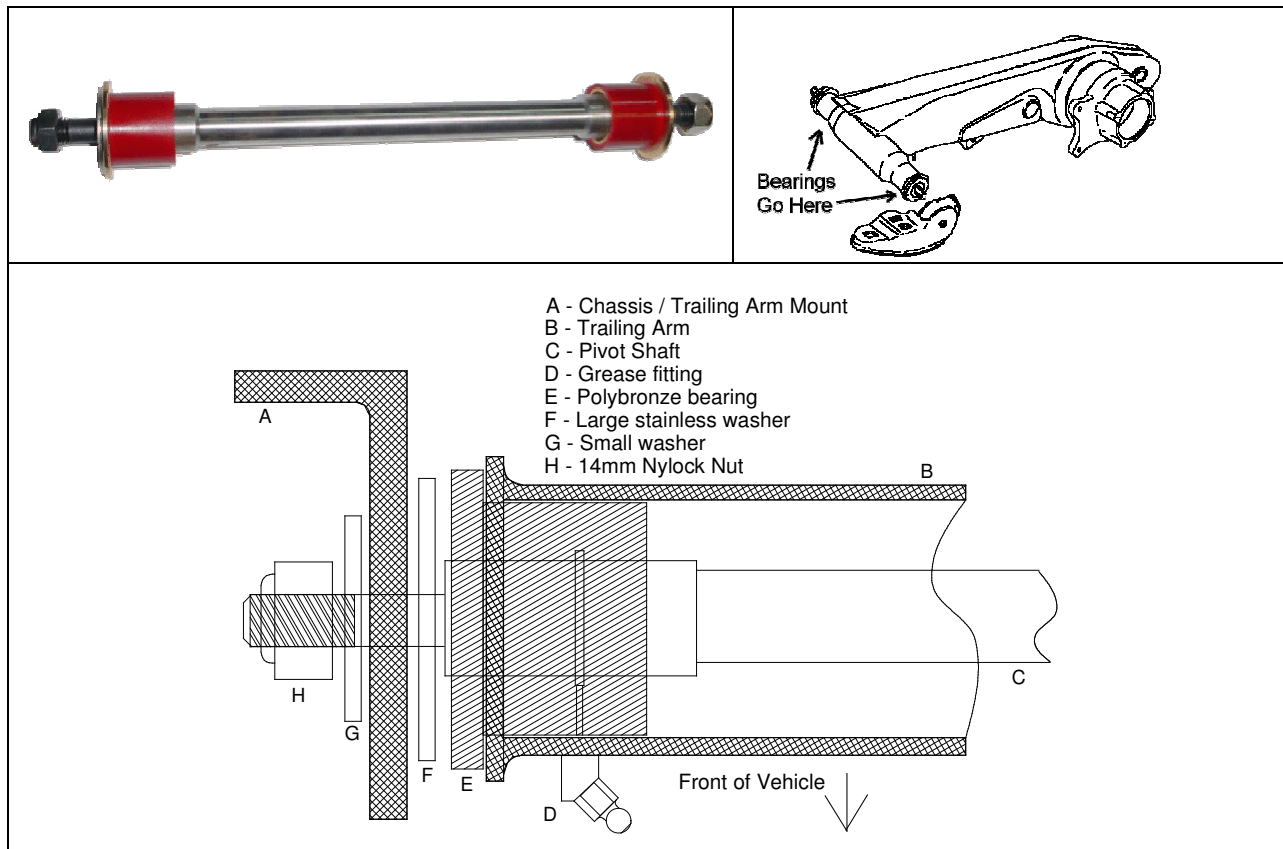

Step-by-Step Installation -

1 – Remove the rubber bushings and pivot shafts.

With trailing arms removed from car, use a hydraulic press to press out the pivot shafts.

If a press is not available, secure trailing arm in a bench vise. Being careful to avoid damaging the trailing arm, drill out the rubber bushings. After drilling away much of the bushing material, the shaft can be easily removed.

Clean residual rubber or grease from the ID of the trailing arm.



2 – Install the bearings.

Lubricate the polyurethane with a soap and water solution to ease installation. Press the bearing into the mount until the flange is fully seated. Do not hammer the bearing into place, use body weight or a pipe clamp to press in. The bearing should be tight and difficult or impossible to turn by hand.

If the bearing is loose in the trailing arm, the fit can be assisted using polyurethane based caulk. Apply a layer between the red polyurethane surface and the trailing arm.



3 – Install grease fittings.

Trailing arm is drilled and tapped. Provided grease fittings are threaded into place, one for each bearing.

With the bearing fully seated, drill a 1/16 inch through-hole through the trailing arm tube and the bearing as shown. Position grease fittings for easy access when installed in car. See suggested locations.

The hole should intersect the circular grease groove in the bearing. Drill the hole 15/16 inch from the bearing flange to intersect the groove.

Drill and tap the hole for M5x.8 threads to a depth of 1/4 inch.

Thread in the grease fitting into place. Point the nipple towards the center of the trailing arm.

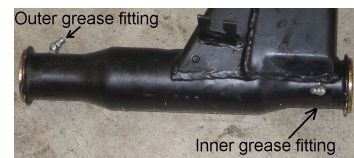

4 – Install trailing arms into car.

Lubricate bearings with quality moly grease.

Install as shown in the diagram. Torque the 14mm nylock bolts to 85 ft/lbs.

Inject some grease into the fittings. Re-lubricate every 5,000 miles or 12 months.

Align car.

